



# SWPPP Cut Sheet

Last Updated: 1-1-08

## Section 2: Storm Water Management – Post Construction

### 2.5 Filtrex EdgeSaver™

#### Streambank and Shoreline Stabilization Technology

#### PURPOSE & DESCRIPTION

The Filtrex EdgeSaver™ vegetated soft armoring system is designed to **stabilize banks, and prevent erosion of waterway and shoreline banks**. The EdgeSaver™ system is composed of a heavy duty tubular mesh netting matrix used to contain and reinforce growing media and vegetation. The EdgeSaver™ technology provides structural protection, erosion control, vegetation growth, and vegetation reinforcement in one system. The EdgeSaver™ weight and anchoring system can withstand storm runoff velocities and hydraulic shear stresses similar to traditional soft armoring devices, while the injected GrowingMedia™ and optional drip tape irrigation system ensure establishment and sustainability of both seeded and live stake plantings. The EdgeSaver™ system will provide: structural stability/protection from toe-cutting and sloughing of waterway bank; structural stability/protection from mass wasting and sloughing of shoreline from wave action; control of erosion from overland runoff, wave action, and shear stress from concentrated flows; control of runoff velocity flowing to receiving water; dissipation of runoff energy flowing to receiving water; sustained vegetation health; sediment, soluble pollutant, and pathogen removal of runoff flowing to receiving water.

#### APPLICATION

The EdgeSaver™ armoring system is used where waterway and shoreline banks are eroding, are unstable, or cannot sustain vegetation. EdgeSaver™ is used to establish and reinforce vegetation where flows and intense hydraulic pressures typically undermine vegetation. Applications include: creek, stream, riparian bank stabilization; pond, lake shoreline stabilization; sediment, storm water retention/detention pond bank stabilization; riparian, stream bank, tidal creek, salt marsh restoration, habitat/ecological restoration, aesthetic revitalization.

#### INSTALLATION

1. Filtrex EdgeSaver™ shall meet Filtrex EdgeSaver™ Specifications and use Filtrex GrowingMedia™.
2. Contractor is required to be a Filtrex Certified™ Installer as determined by Filtrex International, LLC (440-926-2607; www.filtrex.com). Certification shall be considered current if appropriate identification is shown during time of bid or at time of application (list found at www.filtrex.com). Look for Filtrex Certified™ Installer Seal.
3. EdgeSaver™ will be placed at locations indicated on plans as directed by the Engineer and will be fabricated on-site.
4. EdgeSaver™ shall be placed in a manner that protects the entire bank or shoreline from erosion and destabilization.
5. EdgeSaver™ must be installed and stabilized before concentrated flow is allowed to contact bank or slope area.
6. Sediment control devices (such as Filtrex SiltSoxx™) shall be installed if construction requires land disturbance or earth moving.
7. Land surface shall be cleared of debris, including rocks, roots, large clods, and sticks prior to EdgeSaver™ installation.
8. Waterway bank or shoreline shall be made smooth prior to installation of EdgeSaver™; soil bed may be compacted and graded prior to installation.
9. If toe-cutting is an issue at waterway bed and slope interface, excavation should be performed at interface below creek bed level to allow placement of EdgeSaver™ Soxx™
10. Excavation should be to a minimum of 1 ft (300mm) below scour line for streams with flow depths of 6 in (150mm) or greater.
11. An optional geogrid fabric may be anchored to the bank to provide additional bank stability and anchoring surface for the EdgeSaver™ system.
12. On-site fabrication of EdgeSaver™ will ensure a continuous length sock system. Upon completing one section of sock filling (approximately 100-200 ft [30-60m]), the next section shall be 'sleeved' over the completed section by a minimum of 1 ft (300mm). A stake shall be placed in the overlap section, securing the two sections.
13. EdgeSaver™ shall be placed parallel to water flow & perpendicular to wave action, socks are tightly stacked or abutted to prevent water seepage between/underneath system.
14. For stacking and terrace applications, larger diameter EdgeSaver™ Soxx™ will be placed on the bottom of the installation and sequentially smaller diameter EdgeSaver™ Soxx™ placed on top as the construction moves upslope and away from the waterline.
15. Stabilization applications below the waterline will use pea gravel and small rock in the EdgeSaver™ Soxx™ at the base of the EdgeSaver™ system and GrowingMedia™ in the EdgeSaver™ Soxx™ where vegetation will be established above the waterline.
16. In areas where waterline fluctuates below and above the EdgeSaver™ Soxx™ system custom soil blends may be used, as directed by the Engineer. Custom soil blends may include GrowingMedia™, topsoil, sand, pea gravel, or other small aggregate.
17. For EdgeSaver™ terrace applications, areas between EdgeSaver™ Soxx™ should be on a level grade, and backfilled with seeded GrowingMedia™. Waterline should be below terraced areas receiving backfill.
18. Once in place, EdgeSaver™ Soxx™ shall be lightly compacted to tighten seal between socks and encourage even water flow over the surface of the system.
19. EdgeSaver™ shall not be installed on banks or shorelines greater than 1:1, and 3:1 if mowing will be conducted to manage vegetation.
20. Stakes shall be installed through the middle of the EdgeSaver™ Soxx™ on a minimum of 5 ft (1.5m) centers, using 2 in (50mm) by 2 in (50mm) by 3 ft (1m) wood stakes; or
21. L-shaped rebar may be installed through middle of EdgeSaver™ Soxx™ on 5 ft (1.5m) centers, where "L" shall form a hook over top of EdgeSaver™ Soxx™ & pounded snug.
22. Stakes shall also be placed at the ends of EdgeSaver™ Soxx™ to hold it in place.
23. Minimum staking depth for sand and silt loam soils shall be 12 in (300mm), and 8 in (200mm) for clay soils.
24. EdgeSaver™ shall be seeded at the time of application; seeded EdgeSaver™ should not be installed prior to seasons where growing vegetation is difficult.
25. Seed shall be thoroughly mixed with the GrowingMedia™ prior to construction or injected into GrowingMedia™ at time of application.
26. Optional biotechnical engineering with live stakes, tubers, seedlings, or plugs should be conducted after staking is complete.
27. Live stakes should be from a live species and cuttings should be 1 to 3 ft (300-900mm) long.
28. Live stakes should be spaced 5-7 ft (1.5-2.1m) apart, and planted vertically with one end planted through the EdgeSaver™ and at least 2 in (50mm) into native soil.
29. Seeded and/or live staked EdgeSaver™ shall be thoroughly watered after installation and allowed to settle for 1 week.
30. Drip tape may be installed within the EdgeSaver™ Soxx™ during construction to provide irrigation for establishing vegetation (water source should located and secured).
31. If drip irrigation system is installed and municipal water or a pump will be utilized, a pressure reducer may be required to manage flow and prevent drip tape from bursting.

#### INSPECTION and MAINTENANCE

Routine inspection should be conducted within 24 hrs of a runoff event for the first year after installation or until permanent vegetation has established.

1. Seeded EdgeSaver™ shall be maintained until a minimum uniform 70% cover of the applied area has been vegetated or permanent vegetation has established
2. Seeded EdgeSaver™ may need to be irrigated in hot and dry weather and seasons, or arid and semi-arid climates to ensure vegetation establishment.
3. Where EdgeSaver™ fails/becomes dislodged, the Contractor will ensure product is in good contact with the soil and backfill, repair, and use additional staking if necessary.
4. Where bank or shoreline erosion occurs, the Contractor will regrade the soil if necessary and repair or replace the EdgeSaver™
5. Where vegetation does not establish the Contractor will reseed, replant, replace live stakes, or provide an approved and functioning alternative.
6. If EdgeSaver™ is only seeded at time of installation live stakes may be added to increase stability, aesthetics, wildlife habitat, and ecological succession.
7. No additional fertilizer or lime is required for vegetation establishment and maintenance; EdgeSaver™ shall become part of the permanent landscape.
8. Regular mowing of grass vegetation on seeded EdgeSaver™ to a minimum height of 4 in (100mm) and a maximum height of 10 in (250mm) will deter invasive weeds, allow sunlight to kill captured pathogens from storm water, and provide maximum sediment removal efficiency and sediment storage capacity in the vegetation.
9. Storm debris/trash deposited on EdgeSaver™ should be removed immediately; sediment shall be removed if it reaches 25% of the height of the vegetation (mowed).
10. If drip tape irrigation system is installed, once vegetation is fully established, connections to drip tape irrigation system may be removed, leaving the drip tape inside the EdgeSaver™ Soxx™. Cut ends of drip tape and discard in approved waste receptacle.

**Figure 5.1. Engineering Design Drawings for Filtrex EdgeSaver™**

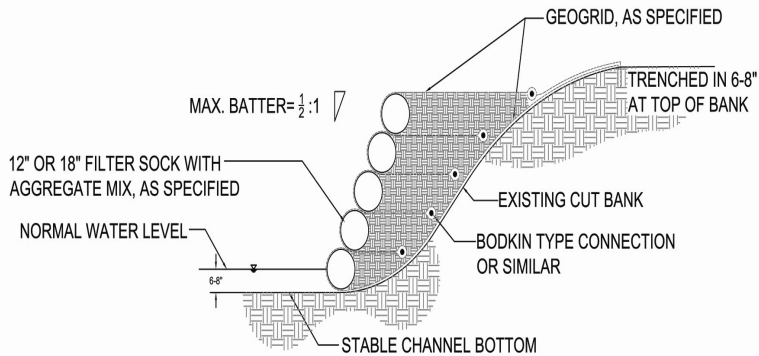
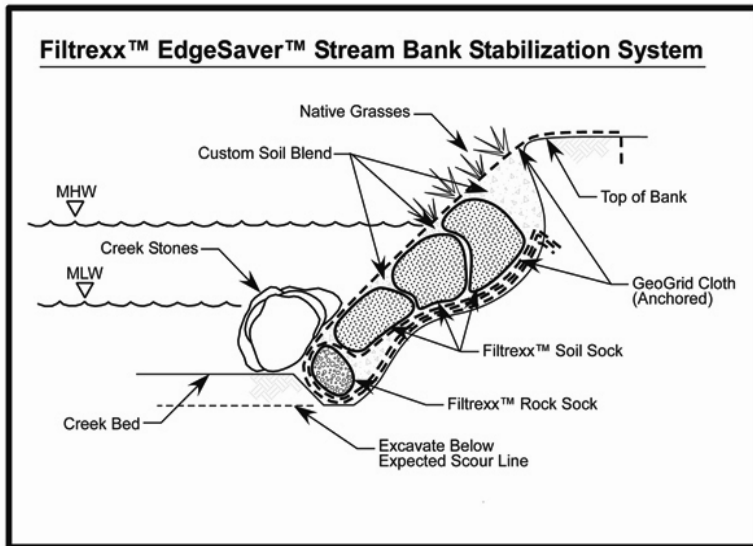

**FILTREX® REINFORCED EDGESAVER™**

NTS

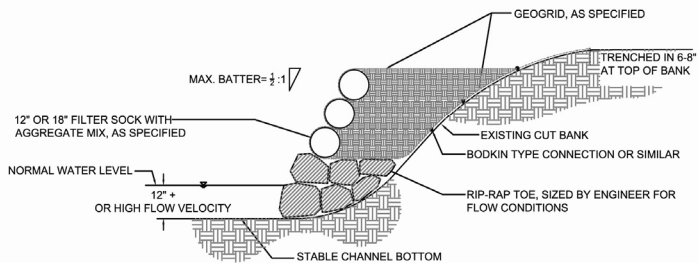

**FILTREX® REINFORCED EDGESAVER™ W/ RIP-RAP TOE**

NTS

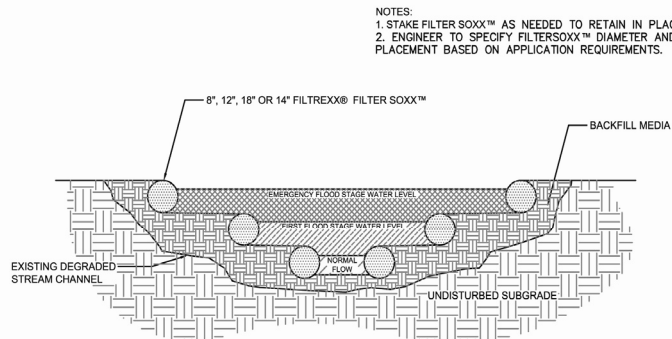

NOTES:  
1. STAKE FILTER SOXX™ AS NEEDED TO RETAIN IN PLACE.  
2. ENGINEER TO SPECIFY FILTERSOXX™ DIAMETER AND PLACEMENT BASED ON APPLICATION REQUIREMENTS.

**FILTREX® EDGESAVER™ TERRACE SYSTEM**

NTS

**Figure 5.2. Staking Details for Filtrex EdgeSaver™**

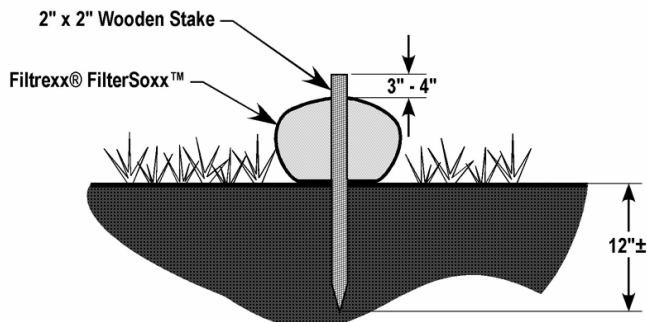
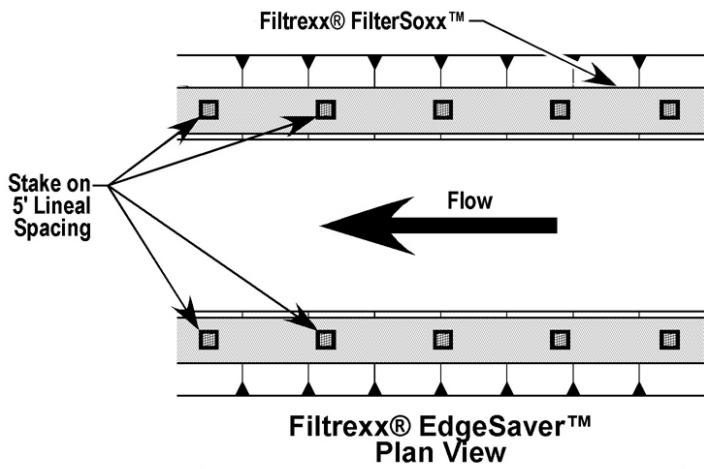

**Filtrex® FilterSoxx™ Section**